

VV



170~2945

VV series nitrogen gas springs feature different dimensions and forces.

VV series nitrogen gas springs are self-lubricated.

VV serisi nitrojen gazlı yaylar farklı boyutlara ve kuvvetlere sahiptir. VV serisi nitrojen gazlı yaylar kendinden yağlamalıdır.



Piston rod
surface roughness Ra - 0.02 µm
surface µ-hardness - 800 HV

Piston kolu
yüzey pürüzlülüğü Ra - 0,02 µm
yüzey µ-sertliği - 800 HV

Wiper ring
Silecek halkası

Rod guide
Piston kolu kılavuzu

Rod seal
Piston kolu keçası

Single-piece body construction
Tek parça monoblok yapısı

O-ring seal
O-ring

Non-return valve
Tek taraflı valf

Side port (charging port)
VV2385 models = M6
VV750 and VV2945 models = G1/8
(other models: charging port at the bottom)
(charge with nitrogen N₂ only)

Yan valf (doldurma valfi)
VV2385 model = M6
VV750 ve VV2945 modellerinde = G1/8
(diğer modeller: doldurma valfi alttadır)
(sadece nitrojen N₂ kullanın)

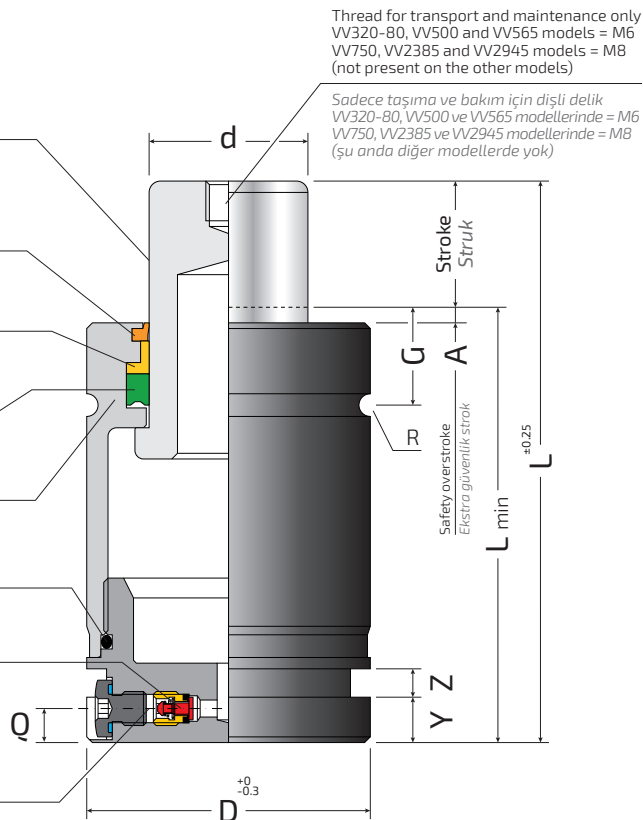

Thread for transport and maintenance only
VV320-80, VV500 and VV565 models = M6
VV750, VV2385 and VV2945 models = M8
(not present on the other models)

Sadece taşıma ve bakım için dişli delik
VV320-80, VV500 ve VV565 modellerinde = M6
VV750, VV2385 ve VV2945 modellerinde = M8
(şu anda diğer modellerde yok)

Technical notes / Teknik notlar

Important use instructions
in the dedicated catalogue section.
Önemli kullanım talimatları özel
katalog bölümünde.

Fixing possibilities / Montaj olasılıkları

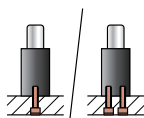

at the base
with screws
alt taraftan
vida(lar) ile

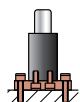

with base-plate
montaj plakası ile
BF, BFA, BFB
for VV750 - VV2945
VV750 - VV2945 için

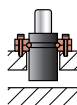

with collar flange
yaka flanş ile
FL, FLQ

(Not for all VV models)
(Bütün VV modeller için değil)



with front support
ön destek ile
FT, FTA

(Not for all VV models)
(Bütün VV modeller için değil)

GAS SPRING BASE / GAZLI YAY TABANI

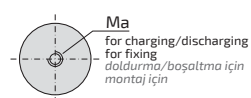

VV170, VV320-63/63H

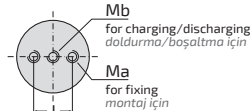

**VV320-80, VV500-63,
VV565-63**

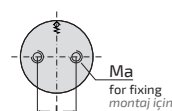

VV750

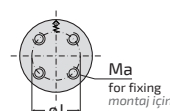

VV2385, VV2945

LINKING TO OPEN SYSTEM / BAĞLANTILI SİSTEMLER

	VV2385 (M6 side port / M6 yan valf)		VV750, VV2945 (G1/8 side port / G1/8 yan valf)		
Hoses Hortumlar	ATM	ATNM	ATM	ATN	AT
Gas spring-hose fittings Gazlı yay - hortum montajları	ARM	ARNM	ARM	ARN	AR

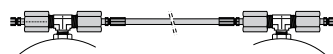

⚠ ATTENTION! Follow the instructions in the "LINKED SYSTEM" section before connecting the gas springs.
DİKKAT! Gazlı yayları bağlamadan önce mutlaka "seri bağlantı" yönergelerini okuyun ve takip edin.

SAFETY PROTECTIONS / GÜVENLİK TEDBİRLERİ



UNCONTROLLED
RETURN SPEED /
KONTROLSUZ GERİ DÖNÜŞ



OVERSTROKE /
AŞIRI STROK



OVERPRESSURE /
AŞIRI BASINÇ

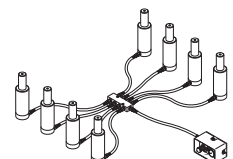

Model Model	MAX Stroke MAKS. Strok mm	Lmin mm	L mm	D mm	d mm	G mm	A mm	R mm	Y mm	Z mm	Q mm	Ma	J mm	Mb	bar (MPa)	daN	daN	Cycles per minute MAX MAKS. dakika başına çevrim	Gas volume Gaz hacmi L	Weight Ağırlık kg
VV170-38	38	97	135														275	80	0.011	0.14
50	50	110	160	19	11	17	1	1	-	-	-	M6 x 10	-	-	180 (18.0)	170	285	60	0.014	0.17
63	63	127	190														285	50	0.017	0.18
VV320-63	63	127	190	25	15	17	1	1	-	-	-	M6 x 9	-	-	180 (18.0)	320	540	50	0.032	0.31
63H	63	145	208														500	50	0.038	0.33
VV320-80	80	125	205	32	15	-	2	-	-	-	-	M6 x 8 (2x)	18	M6	180 (18.0)	320	520	40	0.044	0.44
VV500-63	63	132	195	32	20	-	2	-	-	-	-	M5 x 8 (2x)	15	M6	160 (16.0)	500	830	50	0.058	0.48
VV565-63	63	142	205	32	20	-	2	-	-	-	-	M5 x 8 (2x)	15	M6	180 (18.0)	565	900	50	0.064	0.50
VV750-63	63	113	176	50	25	-	2	-	-	-	10.5	M8 x 13 (2x)	20	-	150 (15.0)	740	1280	50	0.085	1.40
80	80	130	210														1270	40	0.109	2.00
VV2385-80	80	128	208	75	45	21	3	2.5	-	-	6	M8 x 9 (4x)	40	-	150 (15.0)	2385	4250	40	0.33	2.48
100	100	148	248														4300	30	0.41	2.79
VV2945-63	62.5	182.5	245	95	50	-	3	-	-	-	10.5	M8 x 13 (4x)	60	-	150 (15.0)	2945	3950	50	0.70	5.16
80	80	138	218														4850	40	0.47	5.21
100	100	158	258														4850	30	0.60	5.09
125	125	183	308														4800	25	0.75	7.24

All the gas spring models in this table are in accordance with Article 4.3 of the 2014/68/EU Pressure Equipment Directive (PED)

Bu tablodaki bütün gazlı yaylar "2014/68/EU" sayılı "Basınçlı Ekipman Şartnamesinin (PED)" 4.3 numaralı maddesine göre imal edilmişlerdir

"L-VERSION" (FOR LINKED SYSTEM) / "L-VERSİYON" (BAĞLANTILI SİSTEM İÇİN)

When the VV gas springs are to be used in a linked system, make sure to order the "L-version" by adding "-L" after the gas spring code. The "L-version" gas springs are supplied already discharged and without valve, ready for the connection to linked system.
Example: **VV750-80-L**

VV gazlı yaylar bağlantılı bir sistemde kullanılacaksa, gazlı yaylar kodundan sonra "-L" ekleyerek "L-versiyonu" sipariş ettiğinizden emin olun. "L-versiyonu" gazlı yaylar, boş olarak ve valf olmadan montaja hazır halde tedarik edilir.

Örnek: **VV750-80-A-L**

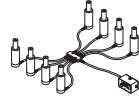

REPAIR KIT / TAMİR KİTİ

Gas spring code Gazlı yay kodu	Repair kit code Tamir kiti kodu
VV170-...	KR/VV170
VV320-63, VV320-63H	KR/VV320-63-63H
VV320-80	KR/VV320-80
VV500-63	KR/VV500
VV565-63	KR/VV565
VV750-...	KR/VV750
VV2385-...	KR/VV2385
VV2945-...	KR/VV2945

Download repair instructions from www.bordignon.com /

Tamir ile ilgili bilgileri www.bordignon.com sitesinden indirebilirsiniz

FORCE RISE VS. USED STROKE LENGTH CHARTS
SAĞLANAN KUVVET / KULLANILAN STROK GRAFİKLERİ

The force curves in the charts below are obtained from reference values measured in static conditions. The actual forces generated under use conditions may vary, since they depend on the specific parameters of the application, such as the working speed (cycles per minute).

Aşağıdaki tablolarda yer alan kuvvet eğrileri, statik koşullarda ölçülen referans değerlerden elde edilmiştir. Kullanım koşulları altında üretilen gerçek kuvvetler, çalışma hızı (çevrim/dakika) gibi uygulamanın özel parametrelerine bağlı olduklarından değişiklik gösterebilir.

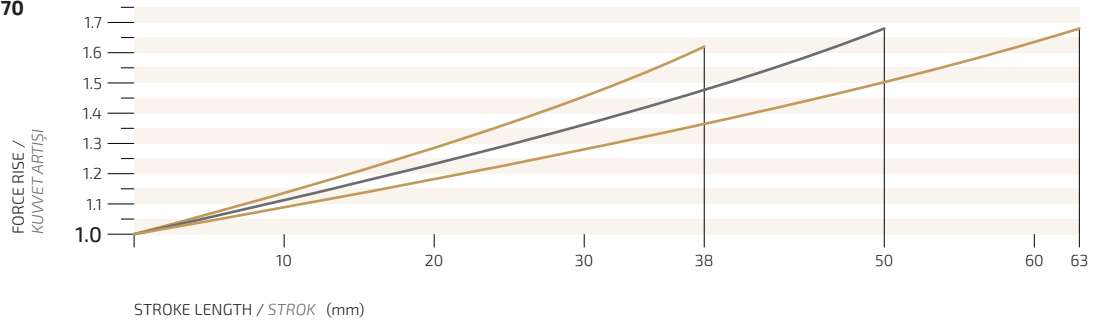
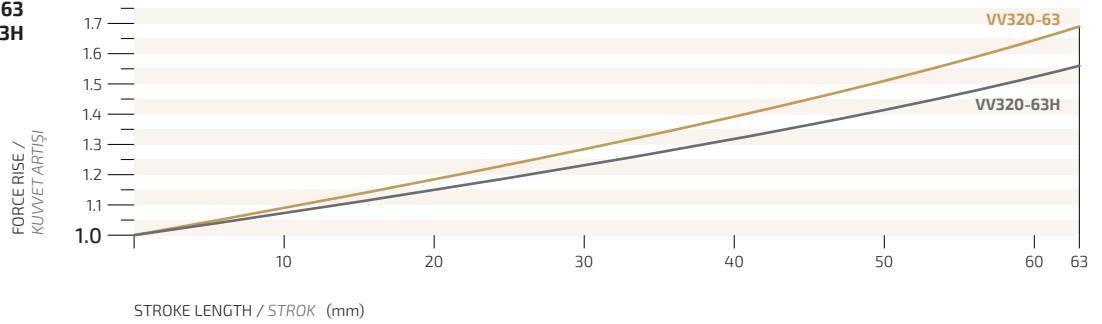
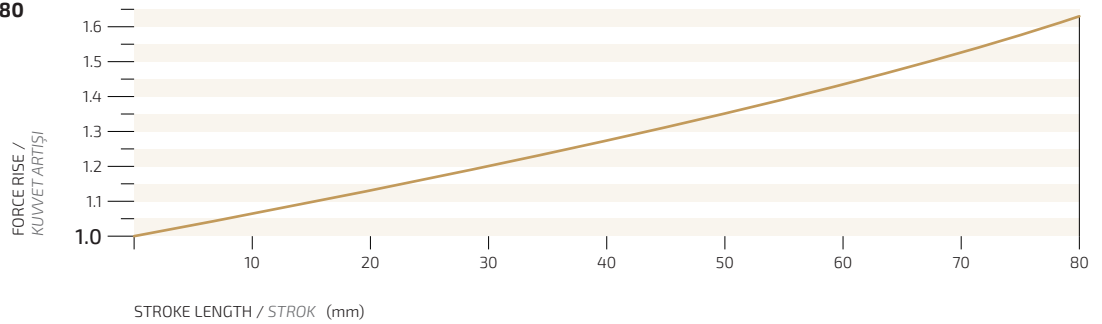
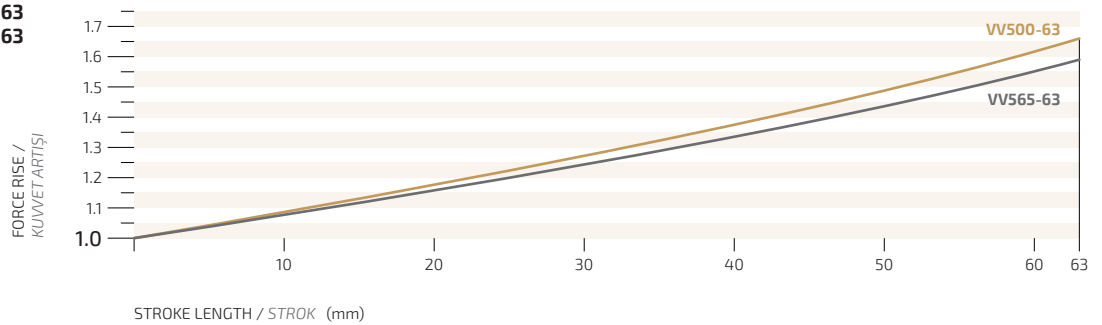
VV170

**VV320-63
VV320-63H**

VV320-80

**VV500-63
VV565-63**

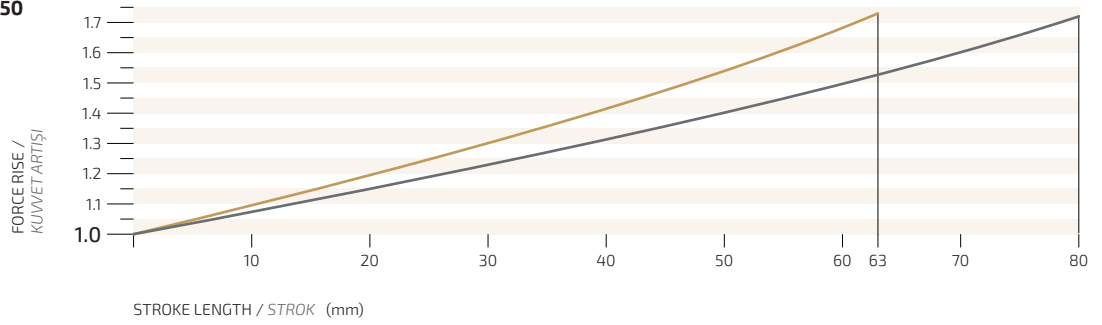
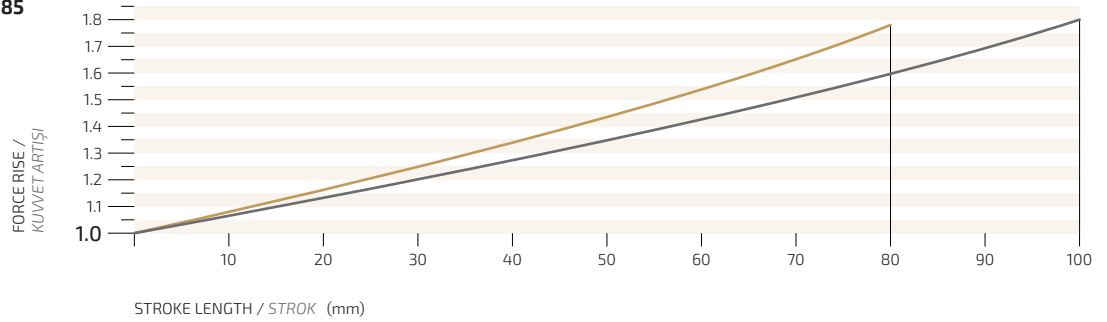
FORCE RISE VS. USED STROKE LENGTH CHARTS
SAĞLANAN KUVVET / KULLANILAN STROK GRAFİKLERİ

The force curves in the charts below are obtained from reference values measured in static conditions. The actual forces generated under use conditions may vary, since they depend on the specific parameters of the application, such as the working speed (cycles per minute).

Aşağıdaki tablolarda yer alan kuvvet eğrileri, statik koşullarda ölçülen referans değerlerden elde edilmiştir. Kullanım koşulları altında üretilen gerçek kuvvetler, çalışma hızı (çevrim/dakika) gibi uygulamanın özel parametrelerine bağlı olduklarından değişiklik gösterebilir.

VV750

VV2385

VV2945
